



G90 Sub-Micro Heading Lock Gyro Instruction Manual

Introduction

The G90 Sub-Micro Heading Lock Gyro's small size (20 x 20 x 15mm) and low weight (9.0 grams, including leads and connectors) make it an ideal choice for a wide variety of micro and mini class electric helicopter models. With features like analog and digital servo support, optional dual remote gain adjustment and Heading Lock or Standard Rate Mode selection capabilities, it offers locked-in tail performance and adjustability perfect for the sport and 3D pilot alike.

Gyro Installation

When installing the G90, it is typically best to first refer to your helicopter's instruction manual for suggestions of the location in which it should be mounted on the model. If no suggestions are available, choose a solid location free from vibration, in-line with the yaw axis of the model. Also, be sure to keep the gyro away from heat generating sources (like the motor and ESC) and other electronics.

When mounting the G90, be sure the side of the gyro with the label is mounted vertically on the model (parallel to the main shaft). The sides of the gyro without the leads and switches are the top and bottom respectively. Also, be sure to position the gyro so you can easily access the gain setting adjustment pot (if not using the remote gain adjustment option), reversing and servo mode switches.

Once you have found a suitable location, use a small amount of isopropyl alcohol to clean the mounting area and gyro where the foam mounting tape will be attached. Then, use the included foam mounting tape to mount the gyro securely on the model. It is important to use foam mounting tape only as it helps to prevent vibration from adversely affecting the performance and operating life of the gyro.

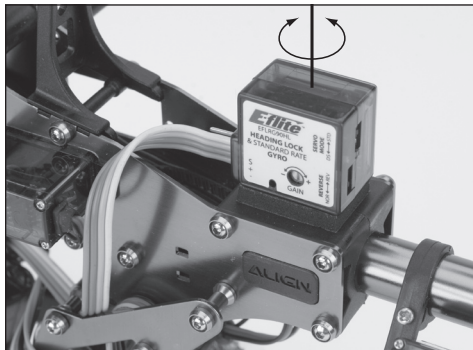

Gyro Connection(s) to Receiver

Single Mode Connection (Heading Lock Mode Only)

If you will **not** be utilizing the dual remote gain adjustment and mode selection option to control gain values and mode type from an auxiliary channel on the transmitter, it will only be necessary to connect the Rudder Channel Lead of the gyro (the connector with three wire leads) to the rudder channel on the receiver. You will not need to connect the Auxiliary Channel Lead of the gyro (the connector with one wire lead) to the receiver, however, to be certain to secure it so it cannot come into contact with any moving parts on the helicopter.

With just the rudder channel lead of the gyro connected to the receiver, the gyro will operate in Heading Lock Mode only. The gain value will then be adjusted using the Gain Setting Adjustment Pot located on the gyro.

Dual Mode Connections (Heading Lock and Standard Rate Mode)

If you have chosen to utilize the dual remote gain adjustment and mode selection option to control gain values and mode type from an auxiliary channel on the transmitter, it will be necessary to connect the Rudder Channel Lead of the gyro (the connector with three wire leads) to the rudder channel on the receiver, and the Auxiliary Channel Lead of the gyro (the connector with one wire lead) to the channel on the receiver that will be used for controlling the gyro from the transmitter. For most radio systems, it will be best to connect the Auxiliary Channel Lead of the gyro to Channel 5 (also known as the Gear Channel) on the receiver, ensuring the yellow wire lead is oriented properly so it is plugged into the "signal" side of the receiver's pins.

With both the rudder channel and auxiliary channel leads of the gyro connected to the receiver, the gyro can be operated in either the Heading Lock or Standard Rate Mode. Mode selection and gyro gain settings will then be adjusted using an auxiliary channel on the transmitter, and the Gain Setting Adjustment Pot located on the gyro will be disabled.

Tail Servo Selection

Selection of a suitable tail servo is critical for obtaining maximum performance from the gyro. A servo with quick transit times (.15 sec/60° or faster) is preferred, and will allow the G90 to perform to its full potential.

We suggest using the following servos in their recommended applications:

- E-flite® S60 Super Sub-Micro Servo (EFLRS60)
– For sub-micro and micro helicopters
- E-flite S75 Sub-Micro Servo (EFLRS75)
– For micro and mini helicopters
- JR 3400G Mini Digital Heli Gyro Servo (JRPS3400G)
– For mini helicopters

Servo Arm and Pushrod Setup

After installing your chosen servo on the model, it will be best to center the servo electronically using an open channel before installing the servo arm and connecting the servo to the G90. Once you have centered the servo electronically, choose a servo arm that allows the tail rotor pushrod linkage or linkage ball to be positioned approximately 8–11mm (typical for T-REX and similar models) from the center of the servo's output gear/shaft. Then, install the servo arm on the servo, ensuring it is perpendicular to the tail rotor pushrod linkage when in the centered/neutral position. Also, be sure to remove any unused portions of the servo arm to prevent any binding or obstruction.

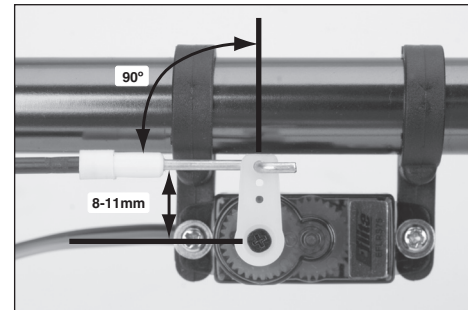

After installing the tail rotor pushrod linkage on the tail servo arm, and ensuring the tail servo is still centered electronically, adjust the length of the pushrod so the tail pitch slider is centered on the tail rotor shaft, between the tail case and tail hub.

Servo Connection to Gyro

Once the tail servo, servo arm and linkage have been installed on the model, it will be necessary to connect the servo to the G90. Connect the servo lead to the servo connection on the gyro (the three pins exiting the gyro case), ensuring proper orientation and polarity direction of the wire leads by following the markings on the label of the gyro:

- S** = Signal wire lead connection location
- +** = Positive wire lead connection location
- = Negative wire lead connection location

Servo Mode Setting

Standard (STD) Servo Mode

If you are using an analog servo (like the E-flite S60 or S75), be sure the Servo Mode switch located on the side of the gyro is set to the Standard (STD) position for the best possible performance. If it is set to the Digital Servo (DS) position, the analog servo may not operate correctly and/or will be damaged due to the high frame rate output of the gyro when it is in the Digital Servo Mode. **Do not use analog servos with the gyro set for Digital Servo Mode.**

Digital (DS) Servo Mode

If you are using a digital servo (like the JR 3400G), be sure the Servo Mode switch located on the side of the gyro is set to the Digital Servo (DS) position for the best possible performance. In the Digital Servo Mode, the gyro sends inputs to the servo at a much higher rate than when in the Standard Servo Mode for added performance and holding power. However, you must be sure to use a digital servo that is capable of handling an input pulse rate of 275Hz or higher (like JR and similar digital servos), or the servo will not operate correctly and/or will be damaged due to the high frame rate output of the gyro when it is in the Digital Servo Mode. **Do not use digital servos that cannot handle an input pulse rate of at least 275Hz, or analog servos, with the gyro set for Digital Servo Mode.**

Initial Transmitter Settings

After completing installation and connection of the G90 and tail servo on the model, please proceed with confirming the following initial settings in your transmitter:

- Set the rudder channel trim and sub-trim (if available) to neutral
- Disable and inhibit any forms of Revolution (Revo) Mixing

Initializing the Gyro

Once you have confirmed the initial settings in the transmitter, it will be necessary to power up and initialize the gyro before proceeding with some of the following setup and adjustment steps:

- Power the transmitter on first.
- Then, power the receiver and gyro on.
- After powering on the receiver and gyro, make sure you do not move or sway the model and allow it to remain motionless until the blue LED on the gyro illuminates solidly, indicating the gyro has initialized properly and is ready for use.

Note: It is extremely important you do not move or sway the model after powering on the gyro and before it initializes. The gyro must be allowed adequate time to record the neutral position in order to initialize for proper operation. If you accidentally move the model after powering the gyro on, and before it has initialized, power the model off and repeat the process to power the model on and initialize the gyro properly.

Heading Lock and Standard Rate Mode Selection and Adjustment

If you have chosen to utilize the dual remote gain adjustment and mode selection option to control gain values and mode type from an auxiliary channel on the transmitter, it will now be necessary to confirm how to select and adjust the Heading Lock or Standard Rate Modes from your transmitter. If you have chosen not to utilize this option, please skip to the next section, as the gyro will always be in the Heading Lock mode.

- With the transmitter, receiver and gyro powered on, enter the transmitter's Travel Adjustment function (also known as ATV or EPA). If, however, you are using a specialized program within your transmitter for controlling the gyro (like Gyro Sensitivity or similar), enter into that particular function.
- Scroll to the channel being used to control the gyro. This will be the same channel into which you have plugged the auxiliary channel lead of the gyro into the receiver.
- Then, using the selected channel's switch on the transmitter, toggle the switch back and forth in order to identify the switch position for each gyro mode. When the gyro is in Heading Lock Mode, you will find the tail servo will not return the neutral position after a rudder input is given. When the gyro is in Standard Rate Mode, the tail servo will always return to the neutral position after a rudder input is given.
- Typically, you will find when the switch is toggled to the positive position (+), the gyro will be in the Heading Lock Mode. Then, when the switch is toggled to the negative position (-), the gyro will be in the Standard Rate Mode.
- Once you have identified the switch position for each mode, note you will be making gain adjustments to the selected mode by changing the Travel Adjustment (ATV/EPA) value for its given switch position.

Initial Gain Settings and Adjustment

Single Mode (Heading Lock Mode Only)

When utilizing the Single Mode option (Heading Lock Mode only), you will make adjustments to the gyro gain value by using the Gain Setting Adjustment Pot located on the gyro itself. Use a small flat blade screwdriver and extreme care (to prevent damage to the pot) to adjust the position of the pot.

When the pot is in the fully counterclockwise position (-), the gain value will be approximately 0%. When the pot is in the full clockwise position (+), the gain value will be approximately 100%.

We suggest a setting of approximately 50% (pot in the middle position) for the first test flight after installing the gyro.

Dual Mode (Heading Lock or Standard Rate Mode)

When utilizing the Dual Mode option (Heading Lock or Standard Rate Mode selectable), you will make adjustments to the gyro gain value in each mode remotely from the transmitter, using the auxiliary channel you have selected for gyro control.

Depending on the transmitter and channel used to control the gyro, you may have the ability to set the Travel Adjustment (ATV/EPA) value from 0% to approximately 100%, or even up to 150%. This is not a problem, as long as you note the maximum value you can set for travel adjustment will equal an actual gain value of 100% for the gyro. In the case of a transmitter and channel that allows you to set the travel adjustment value

up to 150%, you will achieve approximately 50% gyro gain value at a travel adjustment value of 75%, and approximately 100% gyro gain value at a travel adjustment value of 150%.

We suggest setting the gyro gain value to approximately 50% in both the Heading Lock and Standard Rate Modes for the first test flight after installing the gyro.

Confirming Gyro/Servo Operating Direction

It will now be necessary to confirm the tail servo and gyro are operating in the correct directions for proper control. First, refer to the instruction manual included with your helicopter model for information regarding the direction in which the tail servo should respond to rudder inputs for proper control response.

After confirming the tail servo is responding in the correct direction to rudder inputs, you will also need to confirm the gyro is responding properly to movements of the helicopter, while providing proper inputs to the tail servo in order to counteract any unwanted changes in yaw. To do this, view the servo arm (from the top of the servo) and note the direction the arm moves (clockwise or counterclockwise) when you give a right rudder input on the transmitter (while the model remains motionless). Then, yaw the nose of the helicopter quickly to the left, while again noting the direction the tail servo arm moves. The arm should move in the same direction as it did for a right rudder command, helping to counteract the left-hand yaw movement of the nose. If the arm moves in the opposite direction, switch the Reverse switch located on the side of the G90 to its opposite position. Then, repeat the steps above to confirm the gyro is now operating in the correct direction.

Trimming Neutral with Sub-Trim and Trim

When in Heading Lock Mode, the tail servo arm may "creep" or move while the model remains motionless, and with no rudder input from the transmitter. This movement is normal, but can be minimized by adjusting the sub-trim (preferred, if available) or trim value of the rudder channel in/on your transmitter. Use the sub-trim function or trim lever on the transmitter to add a left or right value to the rudder channel. Then, re-center the tail servo arm with the control stick and watch for any additional movement. Add or reduce the sub-trim or trim value as needed until the tail servo arm moves as little as possible when near the neutral position. In general, only a small amount of sub-trim or trim adjustment will be required in order to minimize movement of the tail servo arm (and "drifting" of the nose/tail of the helicopter model in flight), and some very slow movement that may still remain after making the adjustments is normal.

Adjustments After Test Flights

Once you have completed installation and setup of the G90, it will be necessary to conduct test flights in order to identify any settings that must be adjusted so that you can obtain maximum performance of the gyro. Be careful when conducting the initial test flight, however, taking your time to ensure the gyro and tail servo are responding and performing properly before lifting the model into the air.

Gain Adjustments

During the test flight(s), establish a stable hover and apply some short and quick rudder inputs while observing the reaction of the tail when the control stick is returned to its neutral position. If there is any tendency for the tail to twitch quickly (oscillate) from side to side, it will be necessary to lower the gyro gain value. You can do this by adjusting the Gain Setting Adjustment

Pot on the gyro itself counterclockwise a small amount (if using the Single Mode option), or remotely from the transmitter by reducing the Travel Adjustment (ATV/EPA) value for the gyro control channel (if using the Dual Mode option). The goal, when in Heading Lock Mode, is to find the highest gyro gain value at which the tail of the helicopter will not oscillate in all areas of flight, including fast forward flight and descents.

If you are using the Dual Mode option, you will also need to adjust the gyro gain value for the Standard Rate Mode. In this mode, the amount of gyro gain value required will typically depend most on the flying style and preference of the pilot.

Tail Linkage and Pushrod Adjustments

If, after conducting test flights, you find the gyro gain value cannot be set high enough to cause some oscillation of the tail (even at the highest setting), it will be necessary to adjust the position of the tail rotor pushrod linkage on the tail servo arm. In this case, you will need to move the linkage farther out from the center of the servo's output gear/shaft (by approximately 2mm to start).

If you find the gyro gain value cannot be set low enough to prevent oscillation of the tail (when near the lowest setting), it will be necessary to adjust the position of the tail rotor pushrod linkage on the tail servo arm. In this case, you will need to move the linkage closer to the center of the servo's output gear/shaft (by approximately 2mm to start).

If you are using the Dual Mode option, and will be switching between the Heading Lock and Standard Rate Modes during flight, it is best to mechanically adjust the tail rotor pushrod length so there is not a significant difference in the rudder trim/sub-trim values required in each mode for the best performance. This can be accomplished by flying the model in the Standard Rate Mode and adjusting the length of the pushrod so the nose/tail of the model stays as straight as possible, with no rudder input or rudder trim/sub-trim values that are significantly different than those set for optimum performance in the Heading Lock Mode.

Rudder Trim Adjustments

During flight, it may be necessary to make some small adjustments to the rudder trim position/value in order to help prevent the nose/tail of the model from "drifting" to the left or right when the rudder stick is in the neutral position. Typically, only a small amount of adjustment may be necessary.

Rudder Travel Adjustments and Exponential

By increasing or decreasing the left and right Travel Adjustment (ATV/EPA) values for the rudder channel in your transmitter, you can adjust the rate at which the model will pirouette when a full rudder input is given and held, and responds to rudder inputs in general. You can also further fine-tune response of the tail around neutral by increasing or decreasing the amount of Exponential (if available) used for the rudder channel.

Temperature and Environmental Conditions

It is always best to avoid sudden temperature and environmental condition changes when using a gyro. For example, it is best to not fly a model on a very hot day immediately after removing it from an air-conditioned vehicle. It is also best to keep the gyro out of direct sunlight and away from any heat generating sources on the model.

To help the gyro better adapt to temperature and environmental conditions at the flying field, it is best to let the model stand for approximately 10-15 minutes before flying, allowing the temperature inside the gyro to stabilize.

Limited Warranty Period

Horizon Hobby, Inc. guarantees this product to be free from defects in both material and workmanship for a period of 1 year from the date of purchase.

Limited Warranty & Limits of Liability

Pursuant to this Limited Warranty, Horizon Hobby, Inc. will, at its option, (i) repair or (ii) replace, any product determined by Horizon Hobby, Inc. to be defective. **In the event of a defect, these are your exclusive remedies.**

This warranty does not cover cosmetic damage or damage due to acts of God, accident, misuse, abuse, negligence, commercial use, or modification of, or to any part of the Product. This warranty does not cover damage due to improper installation, operation, maintenance, or attempted repair by anyone other than an authorized Horizon Hobby, Inc. service center. This warranty is limited to the original purchaser and is not transferable. In no case shall Horizon Hobby's liability exceed the original cost of the purchased product and will not cover consequential, incidental or collateral damage. Horizon Hobby, Inc. reserves the right to inspect any and all equipment involved in a warranty claim. Repair or replacement decisions are at the sole discretion of Horizon Hobby, Inc. Further, Horizon Hobby reserves the right to change or modify this warranty without notice.

REPAIR OR REPLACEMENT AS PROVIDED UNDER THIS WARRANTY IS THE EXCLUSIVE REMEDY OF THE CONSUMER. HORIZON HOBBY, INC. SHALL NOT BE LIABLE FOR ANY INCIDENTAL OR CONSEQUENTIAL DAMAGES.

As Horizon Hobby, Inc. has no control over use, setup, final assembly, modification or misuse, no liability shall be assumed nor accepted for any resulting damage or injury. By the act of use, setup or assembly, the user accepts all resulting liability.

If you as the purchaser or user are not prepared to accept the liability associated with the use of this product, you are advised to return this product immediately in new and unused condition to the place of purchase.

For additional information concerning the Limited Warranty, Limits of Liability and Safety Precautions, please refer to our web page for this item or contact your E-flite distributor. You can also direct emails to productsupport@horizonhobby.com, or in the U.S., call 877.504.0233 toll free to speak to a service technician.

© 2006 Horizon Hobby, Inc.
www.horizonhobby.com
www.E-fliteRC.com

E-flite® is an exclusive brand of Horizon Hobby, Inc.